

enzie

Z 1500/12

STANDARD SPECIFICATIONS

CONSTRUCTION

The stair is spiral with treads which are made from 3mm Folded Mild Steel treads. Column is 4.9 mm thick by 101.2, 139.7 or 168.3 mild steel. The handrail is tubular 19 or 32 mm OD by 1.6 mm. The stair structure is mechanically jointed on site, requiring no site welding or finishing. The maximum length of any component is slightly more than one meter, and weight is less than 20 kg. The stair can be designed in a clockwise or an anticlockwise direction. The stair baseplate fits on top of the floor surface before or after floor coverings. The pre-finished stair, when erected, is complete; no further finishing is required by others; no unsightly welds.

SURFACE TREATMENT

Internal stairs are supplied pre-finished in a high quality baked polyester powder coating. A range of 21 decorator colours is offered for customer selection with custom colours also available. The handrail, in addition to finishes above, is available in stainless steel. External stairs are supplied Hot Dip galvanized and can be primed with zinc rich epoxy before being finished in baked polyester powder coating.

INSTALLATION

Mechanical jointing and factory pre-finishing of the stair allows installation after all other trades, including floor coverings, have been completed in the stairwell and adjoining area. Installation can be carried out by a local contractor or handyman to installation instructions supplied with stair kit. The stair kit includes all nuts, bolts, installation accessories and an installation instructional Video.

SAFETY

The stair complies with the BCA. The synthetic surface treatment of the stairs are supplied in anti-skid finish. Optional extra gate can be supplied for the top or the bottom of the staircase.

DETAILS OF enzie 1500/14 SPIRAL STAIR

GEOMETRY OF STAIRS

Stair is made with risers between 208 and 220 mm 12 steps to circle at 30°. The going measured at 7/10ths of the clear width is 250mm and slope relationship is between 590 to 680.

TREADS AND RISES Treads are uniform shape and size. Risers are of uniform height between 208 mm and 220 mm as required by client's application. Available tread surfaces include antislip powder-coated steel or Timber treads

HEAD ROOM

Using supplied landing the minimum clear headroom is 2030 mm. Every 1 mm added to riser adds 12 mm to headroom

HANDRAIL

Continuous and uninterrupted handrail is provided on one side and is at a vertical height of 866 mm minimum above the nosing of the tread. Balcony railing is 1000 mm above the floor.

WIDTH

The width of stair free of obstruction is 524mm

BUILDING APPROVALS

Procedure for building approval is to include a copy of this Data Sheet and Accreditation Certificate for the system with drawings showing location of proposed installation (with your required documentation) to the local building authority for their approval. Computations available on request for submission to Building Authority.

PACKED WEIGHT

Approximately 17 kg per riser.

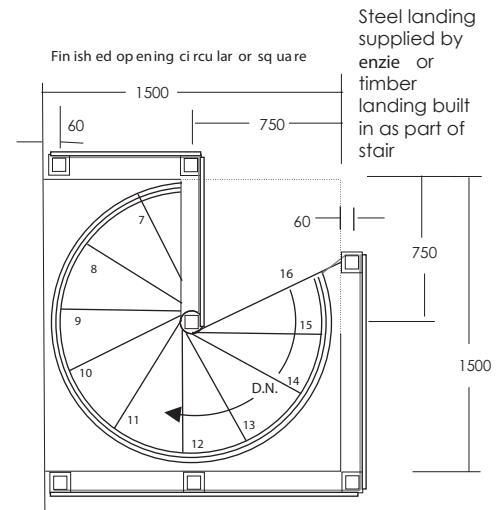

Standard stairwell and Balcony rails

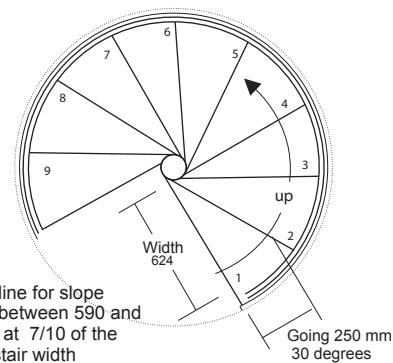
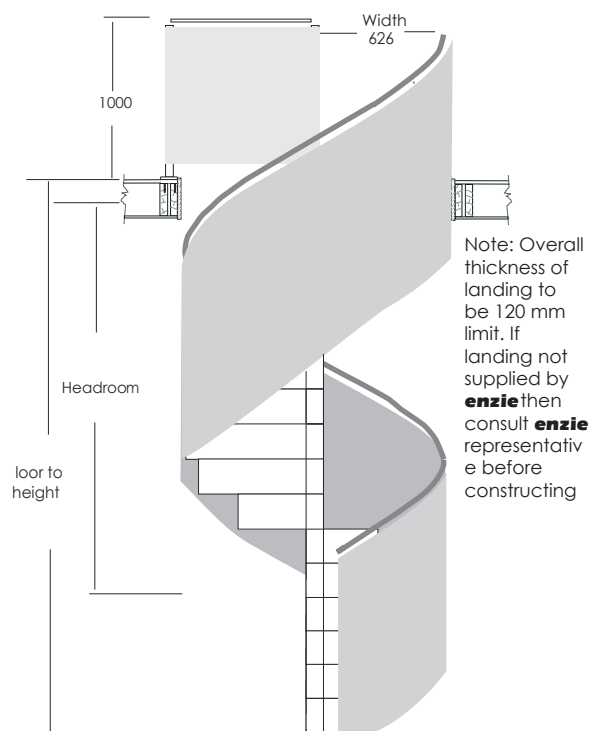

DATA SHEET enzie Z TREAD 1500/12 SPIRAL STAIR

FIXING DETAILS

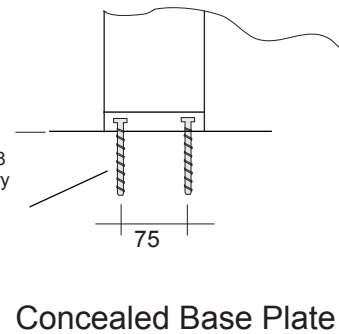
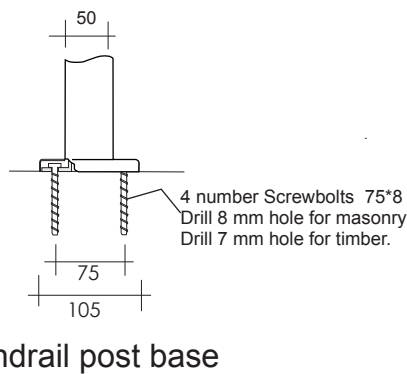
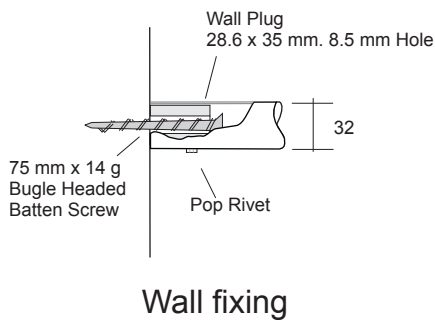
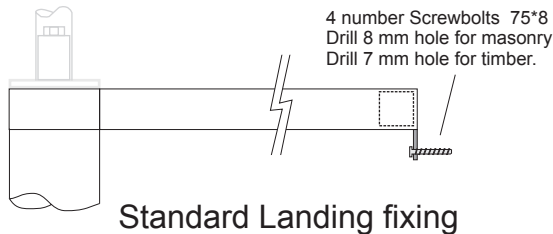

SETTING OUT EXAMPLES

1500/12 208 mm to 220 mm Riser 12 Treads to circle at 30 Degrees

Floor to Floor Height	2640	2860	3080	3300	3520	3740	3960	4180	4400	4620	4840
Number of risers	12	13	14	15	16	17	18	19	20	21	22
Number of treads	11	12	13	14	15	16	17	18	19	20	21
Going	330	360	390	420	450	480	510	540	570	600	630
12 Steps to circle at 30 Degrees											

Some typical top landing examples

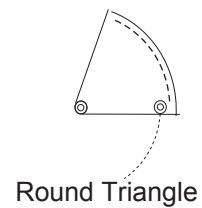
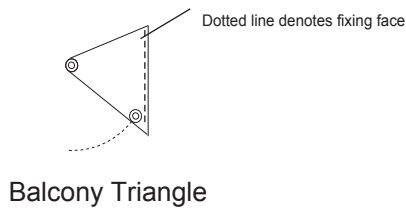
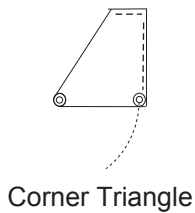

PHOTOS

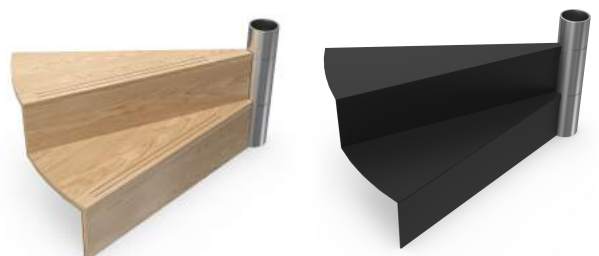
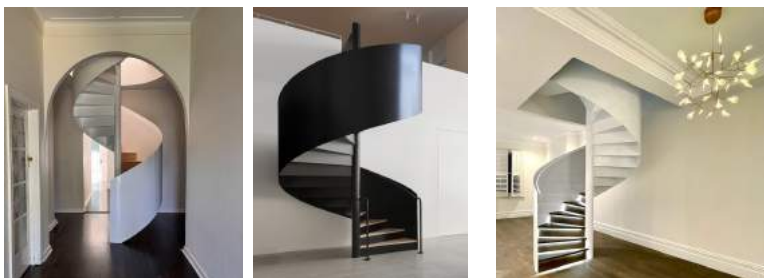

DATA SHEET enzie Z TREAD 1500/12 SPIRAL STAIR

enzie

Z 1500/14

STANDARD SPECIFICATIONS

CONSTRUCTION

The stair is spiral with treads which are made from 3mm Folded Mild Steel treads. Column is 4.9 mm thick by 101.2, 139.7 or 168.3 mild steel. The handrail is tubular 19 or 32 mm OD by 1.6 mm. The stair structure is mechanically jointed on site, requiring no site welding or finishing. The maximum length of any component is slightly more than one meter, and weight is less than 20 kg. The stair can be designed in a clockwise or an anticlockwise direction. The stair baseplate fits on top of the floor surface before or after floor coverings. The pre-finished stair, when erected, is complete; no further finishing is required by others; no unsightly welds.

SURFACE TREATMENT

Internal stairs are supplied pre-finished in a high quality baked polyester powder coating. A range of 21 decorator colours is offered for customer selection with custom colours also available. The handrail, in addition to finishes above, is available in stainless steel. External stairs are supplied Hot Dip galvanized and can be primed with zinc rich epoxy before being finished in baked polyester powder coating.

INSTALLATION

Mechanical jointing and factory pre-finishing of the stair allows installation after all other trades, including floor coverings, have been completed in the stairwell and adjoining area. Installation can be carried out by a local contractor or handyman to installation instructions supplied with stair kit. The stair kit includes all nuts, bolts, installation accessories and an installation instructional Video.

SAFETY

The stair complies with the BCA. The synthetic surface treatment of the stairs are supplied in anti-skid finish. Optional extra gate can be supplied for the top or the bottom of the staircase.

DETAILS OF enzie 1500/14 SPIRAL STAIR

GEOMETRY OF STAIRS

Stair is made with risers between 208 and 220 mm 12 steps to circle at 30°. The going measured at 7/10ths of the clear width is 217mm and slope relationship is between 590 to 680.

TREADS AND RISES

Treads are uniform shape and size. Risers are of uniform height between 208 mm and 220 mm as required by client's application. Available tread surfaces include antislip powder-coated steel or Timber treads

HEAD ROOM

Using supplied landing the minimum clear headroom is 2030 mm. Every 1 mm added to riser adds 12 mm to headroom

HANDRAIL

Continuous and uninterrupted handrail is provided on one side and is at a vertical height of 866 mm minimum above the nosing of the tread. Balcony railing is 1000 mm above the floor.

WIDTH

The width of stair free of obstruction is 524mm

BUILDING APPROVALS

Procedure for building approval is to include a copy of this Data Sheet and Accreditation Certificate for the system with drawings showing location of proposed installation (with your required documentation) to the local building authority for their approval. Computations available on request for submission to Building Authority.

PACKED WEIGHT

Approximately 17 kg per riser.

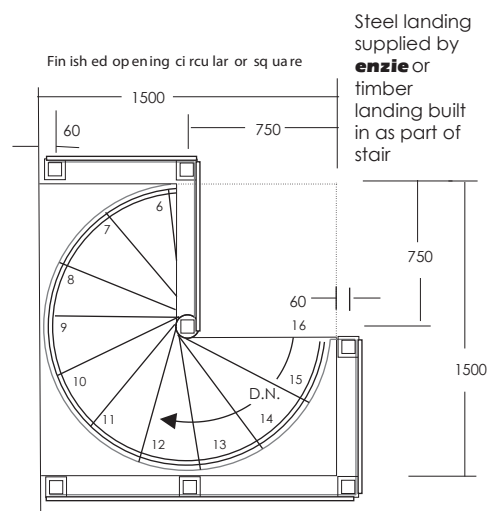

Standard stairwell and Balcony rails

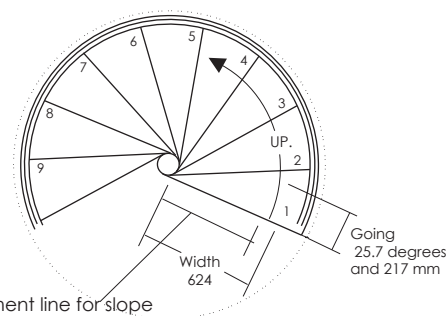
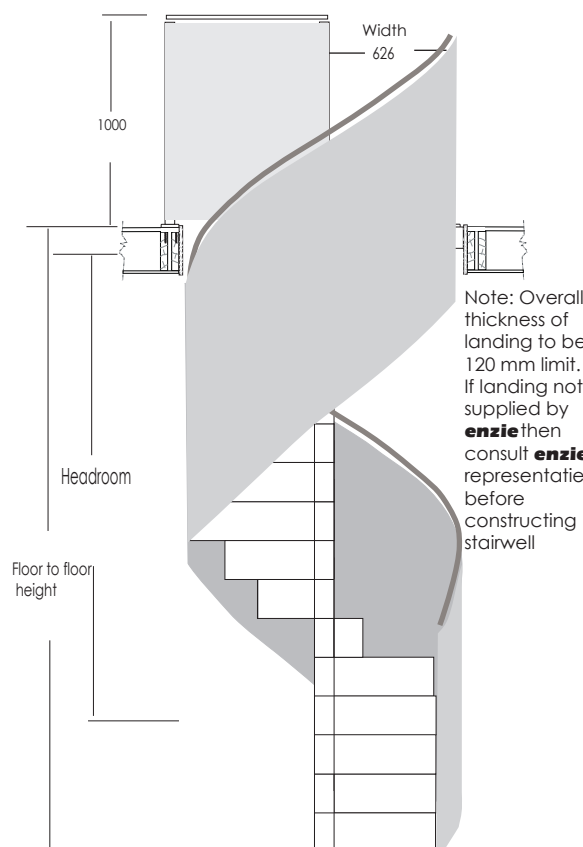

Measurement line for slope relationship is between 590 and 680 measured at 7/10 of the unobstructed stair width

DATA SHEET enzie Z TREAD 1500/14 SPIRAL STAIR

