

**STANDARD SPECIFICATIONS
CONSTRUCTION**

The stair is spiral with tapered box-section treads which are made from 2 mm and 1.6mm mild steel. Column is 4.9mm thick by 101.2mm diameter mild steel. The handrail is tubular 19mm OD by 1.6mm mild steel and balusters are 16mm OD by 1.6mm steel. The stair structure is mechanically jointed on site, requiring no site welding or finishing. The maximum length of any component is slightly more than one metre, and weight is less than 15kg. The stair can be assembled in a clockwise or an anticlockwise direction. The stair base-plate fits on top of the floor surface before or after floor coverings. The pre-finished stair, when erected, is complete; no further finishing is required by others; no unsightly welds, nuts or bolts are showing.

SURFACE TREATMENT

Internal stairs are supplied pre-finished in a high quality baked polyester powder coating. A range of 21 decorator colours is offered for customer selection. The handrail, in addition to finishes above, is available in stainless steel. External stairs are supplied galvanized and primed with zinc rich epoxy before being finished in baked polyester powder-coating.

INSTALLATION

Mechanical jointing and factory pre-finishing of the stair allows installation after all other trades, including floor coverings, have been completed in the stairwell and adjoining area. Installation can be carried out by a local contractor or handyman to installation instructions supplied with stair kit. The stair kit includes all nuts, bolts, installation accessories and an installation instructional DVD.

SAFETY

The synthetic rubber anti-skid pad, applied to the top of stair treads ensures safe access. All balusters on the staircase are spaced as standard at a maximum of 125mm. A steel tube reduces the gap under each tread to less than 125mm at the tapered end of the tread. An optional extra gate can be supplied for the top or the bottom of the staircase.

DETAILS OF enzie 1500mm DIAMETER SPIRAL STAIR

GEOMETRY OF STAIRS

Stair is made with risers between 208 and 220mm 14 steps to circle at 25.7 degrees. The going measured at 7/10ths of the clear width is 219mm and slope relationship is 639 to 659.

TREADS AND RISES

Treads are uniform shape and size. Risers are of uniform height between 208mm and 220mm as required by client's application. Anti-skid pad for each tread is supplied. This pad is replaceable if wear should occur.

HEAD ROOM

Using standard 60 degree landing 120mm thick with 210 mm riser clear headroom is 2030mm. Every 1 mm added to riser adds 12 mm to headroom.

HANDRAIL

Continuous and uninterrupted handrail is provided on one side and is at a vertical height of 866mm above the nosing of the tread. Balcony railing is 1000mm above floor.

WIDTH

The width of stair free of obstruction is 626mm.

BUILDING APPROVALS

Procedure for building approval is to include a copy of this Data Sheet and Accreditation Certificate for the system with drawings showing location of proposed installation (with your required documentation) to the local building authority for their approval. Computations available on request for submission to building Authority.

PACKED WEIGHT

Approximately 16kg per riser.

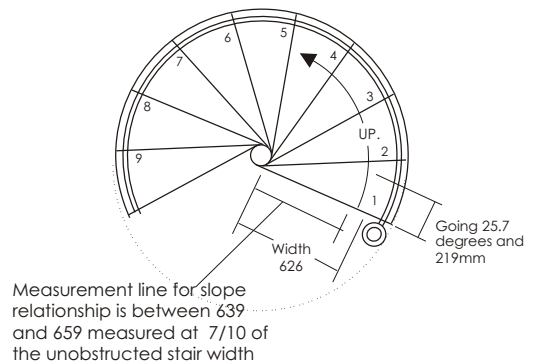
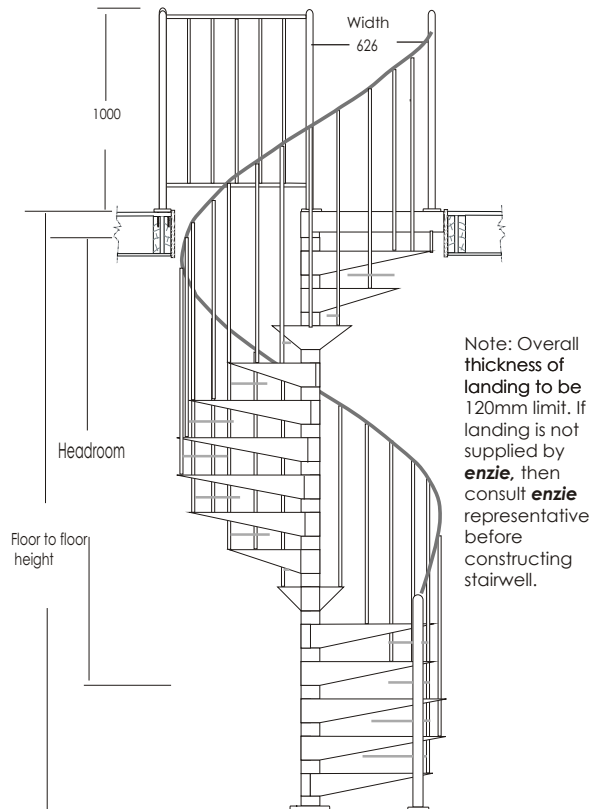
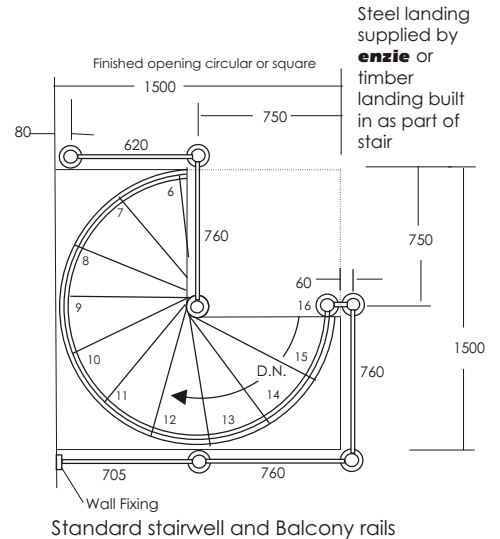

DATA SHEET enzie H-S 1500/14 SPIRAL STAIR



Fixing Detail

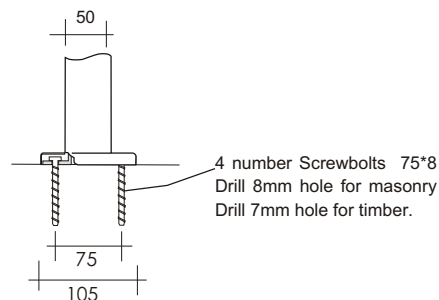
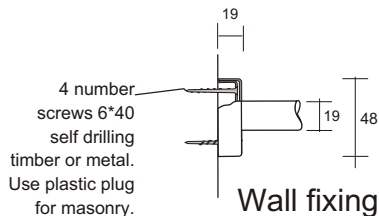

Top fixing TFN 90 type standard.

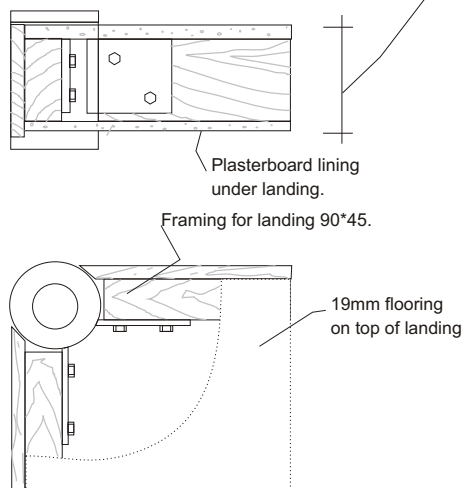

Handrail post base

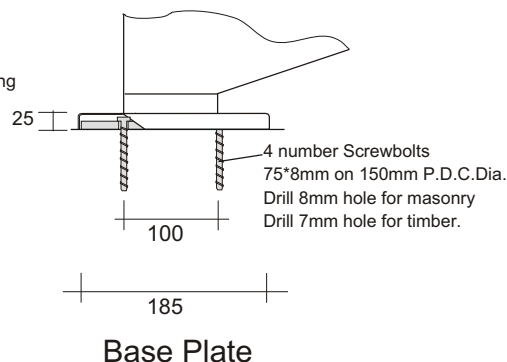

Setting out examples

1500 Diameter 208mm to 220mm Riser 14 Treads to circle at 25.7 Degrees

Floor to Floor Height	2640	2860	3080	3300	3520	3740	3960	4180	4400	4620	4840
Number of risers	12	13	14	15	16	17	18	19	20	21	22
Number of treads	11	12	13	14	15	16	17	18	19	20	21
Going	282	308	334	360	385	411	437	463	488	514	540
14 Treads to circle at 25.7 Degrees											

Some typical top landing examples

